

# RHINO GRATING

---

The Professional Choice



**RHINO**  
GRATING

[www.rhino-grating.com.au](http://www.rhino-grating.com.au)

# A Unique Product

## Product range designed for the International Market

Our manufacturing factory boasts an extensive product range with a simplified key range of options packaged specifically for the International Market.

RHINO GRATING product groups:

- Load bar centres:
  - 30mm load bar centres for high foot traffic.
  - 40mm load bar centres for low foot traffic.

*Important Please note: we can supply 60mm centres but this size does not meet AS/NZ standards for elevated platforms.*

## Long-term cost savings

Multi-purpose utility and diversity in application are some of the best attributes a product can offer, and the RHINO GRATING products certainly offer these. Grating has many uses – not only in industry as walkway flooring but also as screens, drain covers and stairways.

*Better still, RHINO GRATING is unique!*

Similar to a steel 'I Beam' where the strength is in the flanges, the bar profile gives around 25% weight reduction while retaining strength.

This design saves not only weight, but also material cost and galvanising cost. Savings are also made in the design of the supporting structure for the grate, as the product is so much lighter and stress is reduced.

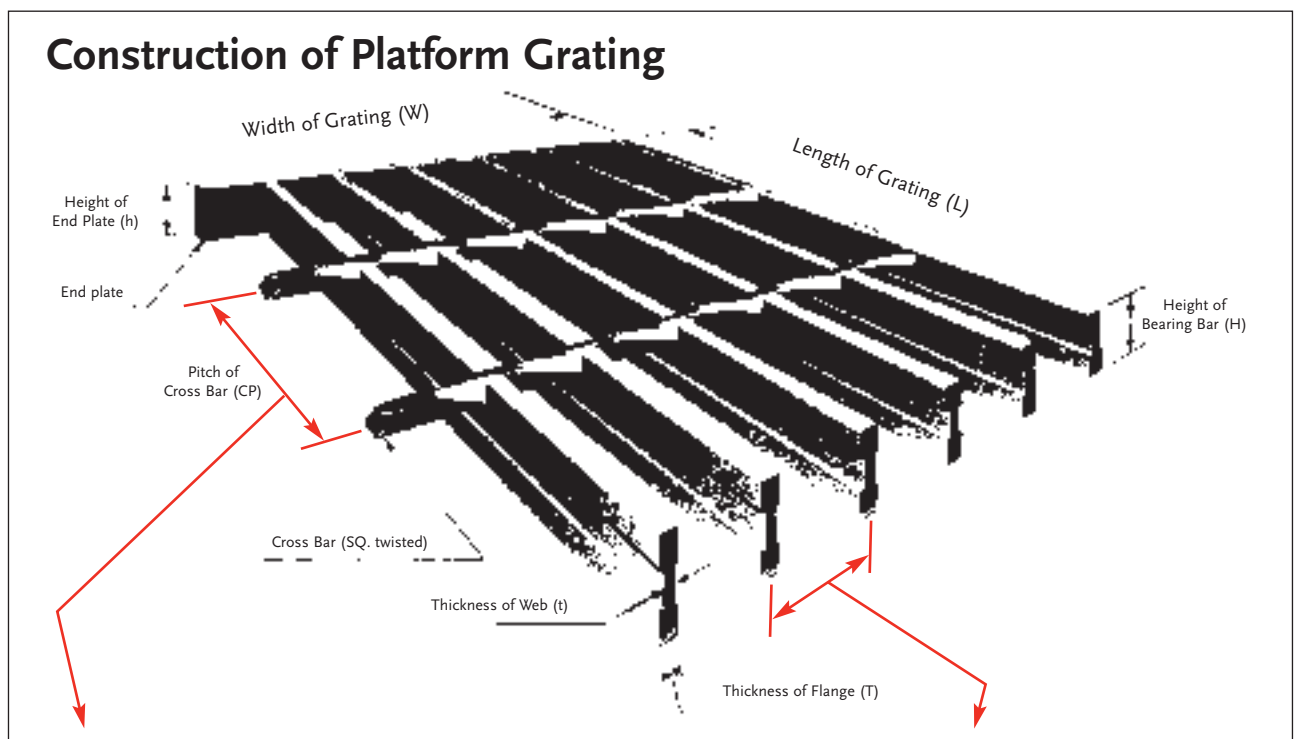

### Pitch of Cross Bar

The centre distance between two cross bars adjacent to each other is called pitch of cross bar. Standard pitch is 100mm.

### Pitch of Bearing Bar

The centre distance between two bearing bars adjacent to each other is called pitch of bearing bar. Standard pitch is 30mm (Series 1), 40mm (Series 2).

# Grating Types

## I Bar or Flat Bar Grating

The bearing bar comes in the form of an I-Section. This type of grating is used where high strength is required and light weight is critical. Commonly used for platforms and walkways.

RG 253	RG 323	RG 2553	RG 3253	RG 3853	RG 5053

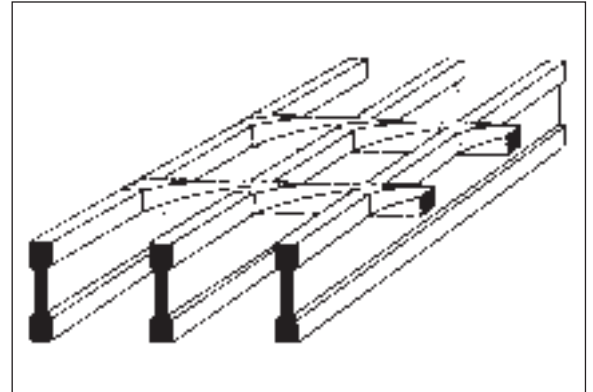

**Please note:** • Load bar sizes range from 20mm to 100mm depth  
• Load bars are available in both FLAT BAR and I BAR

## Serrated Type I Bar Grating

The bearing bar comes in the form of an I-Section with the top surface formed by a series of notches. In addition to its high strength and light weight, this type of grating also has non-slip characteristics. Serrations are rolled on to meet strict health and safety requirements and contain sharp edges. Hot rolled serrations helps stop lacerations if someone falls on the grating.

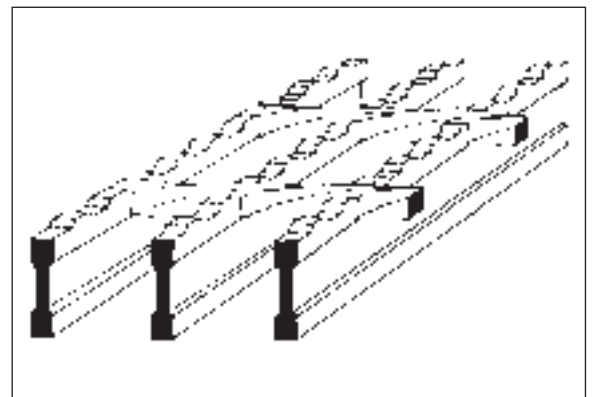

Sydney Tower Tourist Walk

# How to order Rhino Grating

## Stock Panels ready to use off the shelf

We carry a full range of off the shelf stock panel sizes. All panels are 5.8 x 1m (Nominal) sizes range from 20mm load bar to 75mm load bar and come in both series I and series II. Please contact us for sizes and availability of the quantity you require.

## Made to order

Rhino Grating provides tailored solutions to meet your construction requirements.

What we require from the client:

- Type of load bar required
- Load bar centres (ie. 30mm, 40mm)
- Load bar directions
- Cutouts fully diamentioned
- Kick plate detail if any
- Clip requirements



Container Loading Dock

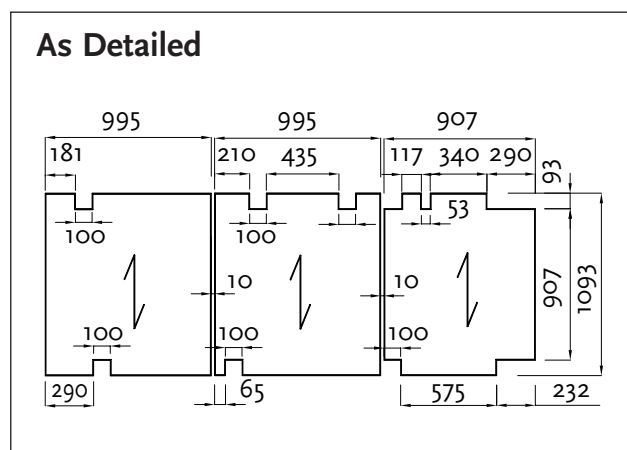
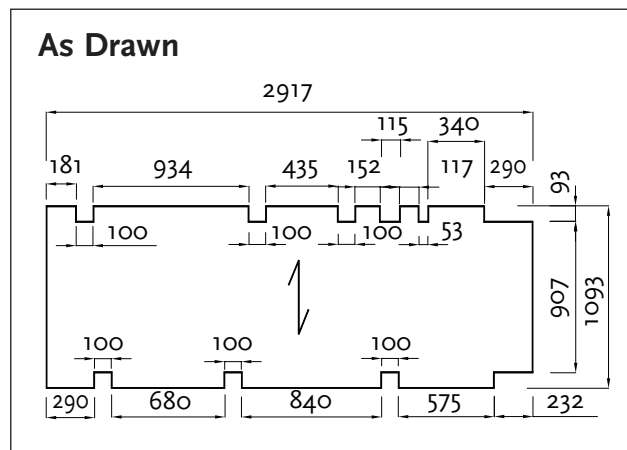

Platform Top View



# International Standards Guaranteed

When quality is the cornerstone of all operations, standards must follow international benchmarks.

Supplied throughout Australasia RHINO GRATING is made to international standards and the factory is accredited to **ISO 9001:2000**.

The ISO 9001:2000 is an international quality management system involving external audits and stringent quality management criteria.

Our factory has high manufacturing tolerances. This is shown in the unique vertical alignment of the load bars resulting in a stronger, better-looking product for our customers.

The standard applicable for galvanising is **AS/NZS 4680 – Hot Dip Galvanized (zinc) coatings on fabricated ferrous articles**.

## Manufacturing Tolerances

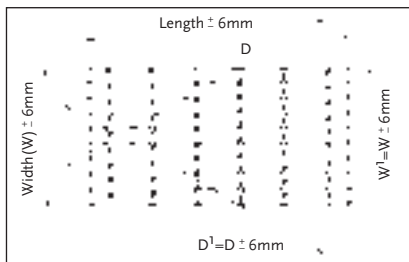

W and W<sup>1</sup> are overall lengths of cross bars at opposite ends of panel.

D and D<sup>1</sup> are overall diagonal dimensions

### Transverse Bow

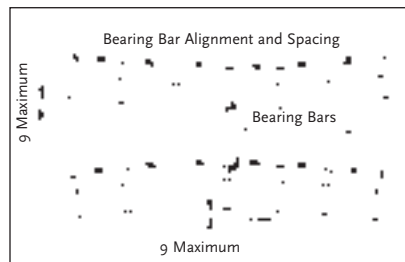

### Longitudinal Bow

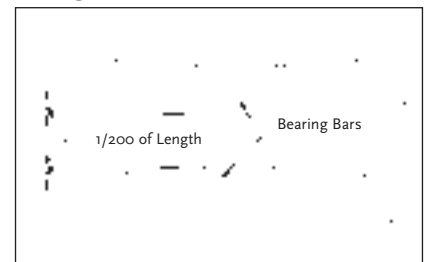

### Cross Bar Location and Bearing Bar

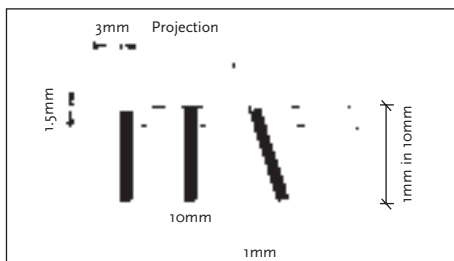

# FRP

## Moulded FRP Grating

Fibre Reinforced Plastic (FRP) gratings are widely used as trench covers, grills, flooring, platforms, ramps, pet covers, tower packing supports, walkways, stairs, battery racks, screens, bridges, railings, machinery guards, wash racks, etc. in the industries of chemical, petroleum, electronics, paper, printing & dyeing, water treatment, pollution control, offshore, power, brewing, etc.

- Sheet sizes are 1220 x 3660
- Cut to order or standard stock panels
- 25mm Depth
- 38mm Depth
- 50mm Depth
- Available in both isophthalic or vinylester resin
- anti slip grit top standard

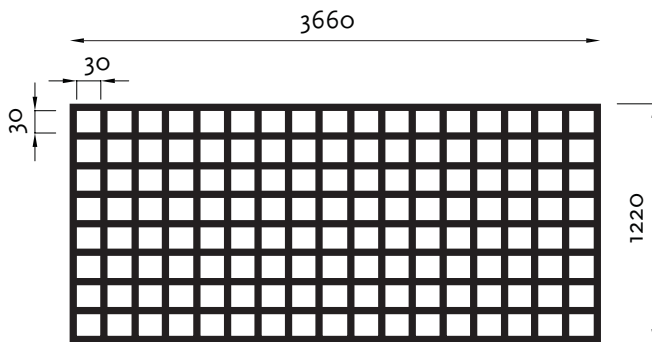

Full size off shelf panel

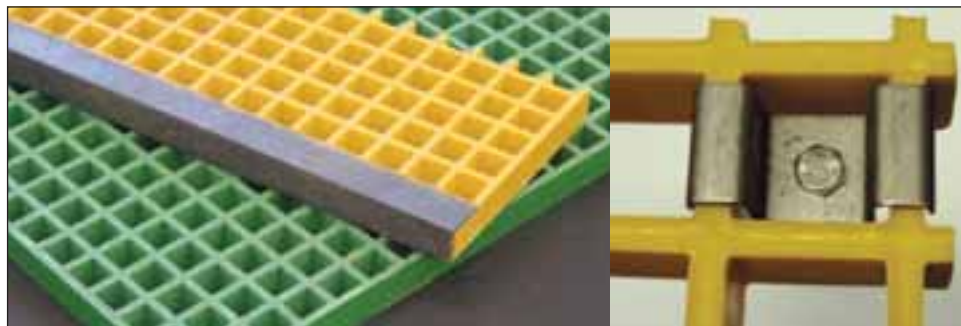

### LOAD AND DEFLECTION TABLE - FRP

This table is theoretical and is based on uniformly distributed load of 300kg/m<sup>2</sup> (3kPa)

Product Code	Load Bar (mm)	Bar Centres (mm)	Mass kg/m <sup>2</sup>	Span (mm)					
				600	750	900	1050	1200	
FRP25	25 x 6	38 x 38	12.1	D	1.3	3.1	7.6	13.1	18.6
FRP38	38 x 6	38 x 38	18.6	D	0.3	1.1	2.1	3.8	5.6

Note: For uniformly distributed load other than 300kg/m<sup>2</sup> (3kPa) grating deflection can be calculated using the factor shown in the following table.

#### Stress and Deflection Factor

Uniform Load kg/m <sup>2</sup>	200	250	300	400	500
Factor (i)	0.67	0.83	1.00	1.33	1.67

S = Stress in kg / mm<sup>2</sup>

D = Deflection in mm

Allowable Stress = 18kg/mm<sup>2</sup> (180MPa)

Allowable Deflection = L(Span) / 300mm

#### Sample Calculation

Uniform Load: 200kg/m<sup>2</sup> (2kPa)

→ factor (i) of 0.67

Grating Code: FRP25

Span: 900mm

Deflection(D) = 7.6 x 0.67 = 5.1mm

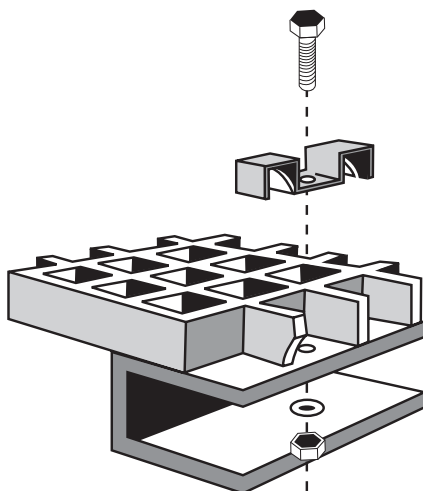

# Stair Treads

## Made to Order

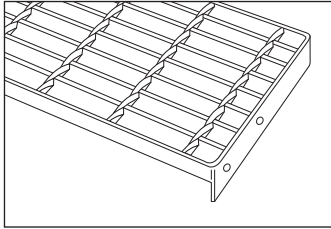

**T1**  
Welded  
Banded only

**T2**  
Bolted  
end plates

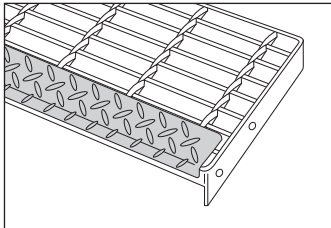

**T3**  
Welded  
Banded only  
with checker  
plate nosing

**T4**  
Bolted  
plates with  
checker  
plate nosing

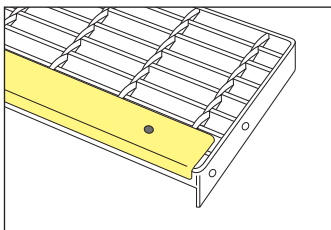

**T5**  
Welded  
Banded only  
abrasive  
nosing

**T6**  
Bolted  
end plates  
abrasive  
nosing



## Made to Order Stair Treads or Off the Shelf Stair Treads

Rhino Grating has a range of off the shelf stair treads. This saves time and cost.

RECOMMENDED MAX. SPANS FOR GRATING PATTERNS				
LOAD BAR SIZE	25 X 3	25 X 5	32 X 5	40 X 5
SERIES I 30mm	550	900	1300	1600
SERIES II 40mm	450	750	1200	1500

STAIRTREADS, THE GRATING SIZE MUST BE NOMINATED.

Length (mm)	Width (mm)	Bolted or Welded	Checker plate nosing	32x5 I Bar 30mm Centres
600	305	✓	✓	✓
650	305	✓	✓	✓
700	305	✓	✓	✓
750	305	✓	✓	✓
800	305	✓	✓	✓
850	305	✓	✓	✓
900	305	✓	✓	✓
950	305	✓	✓	✓
1050	305	✓	✓	✓

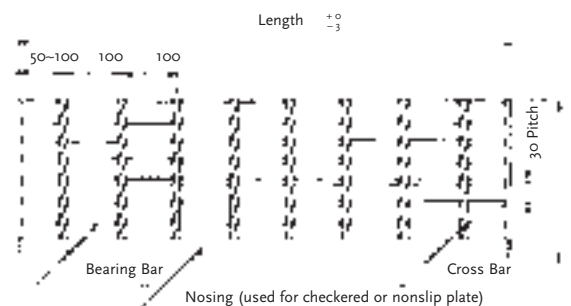
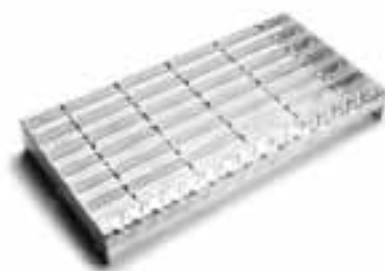



# A Walkway System

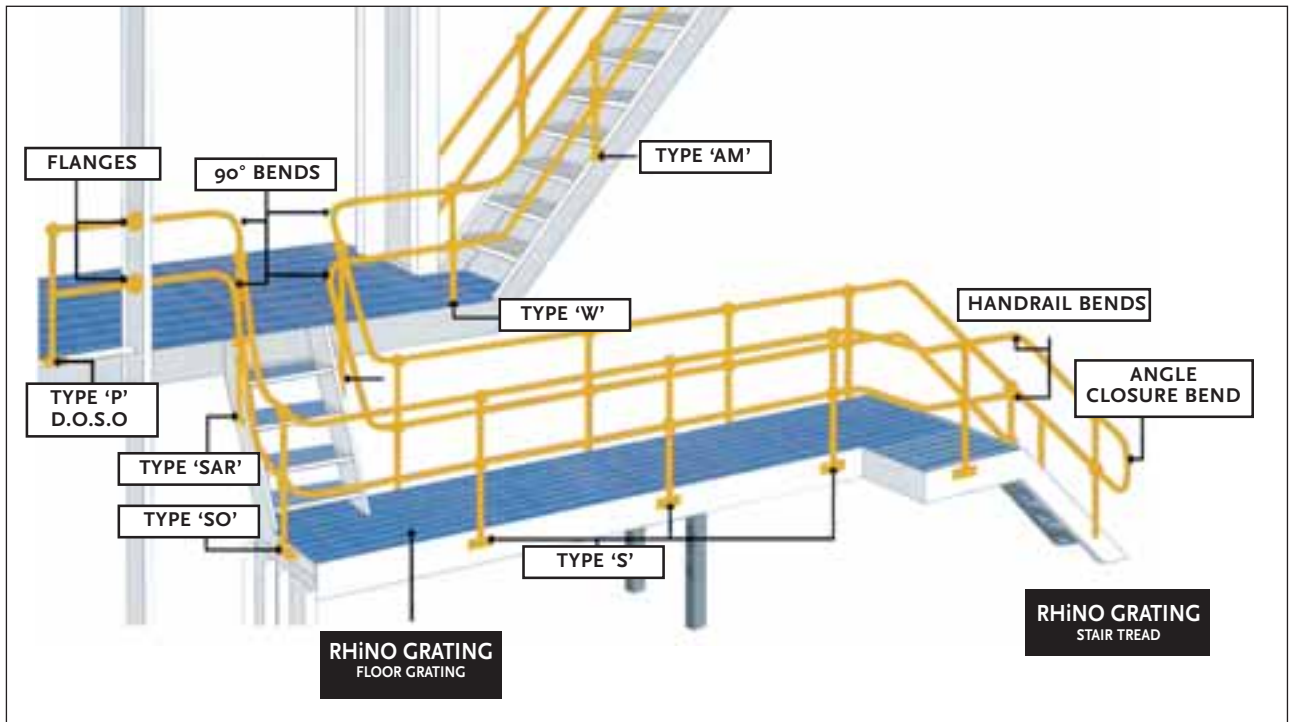

*Pohokura Oil Platform*



# Standard Stanchions

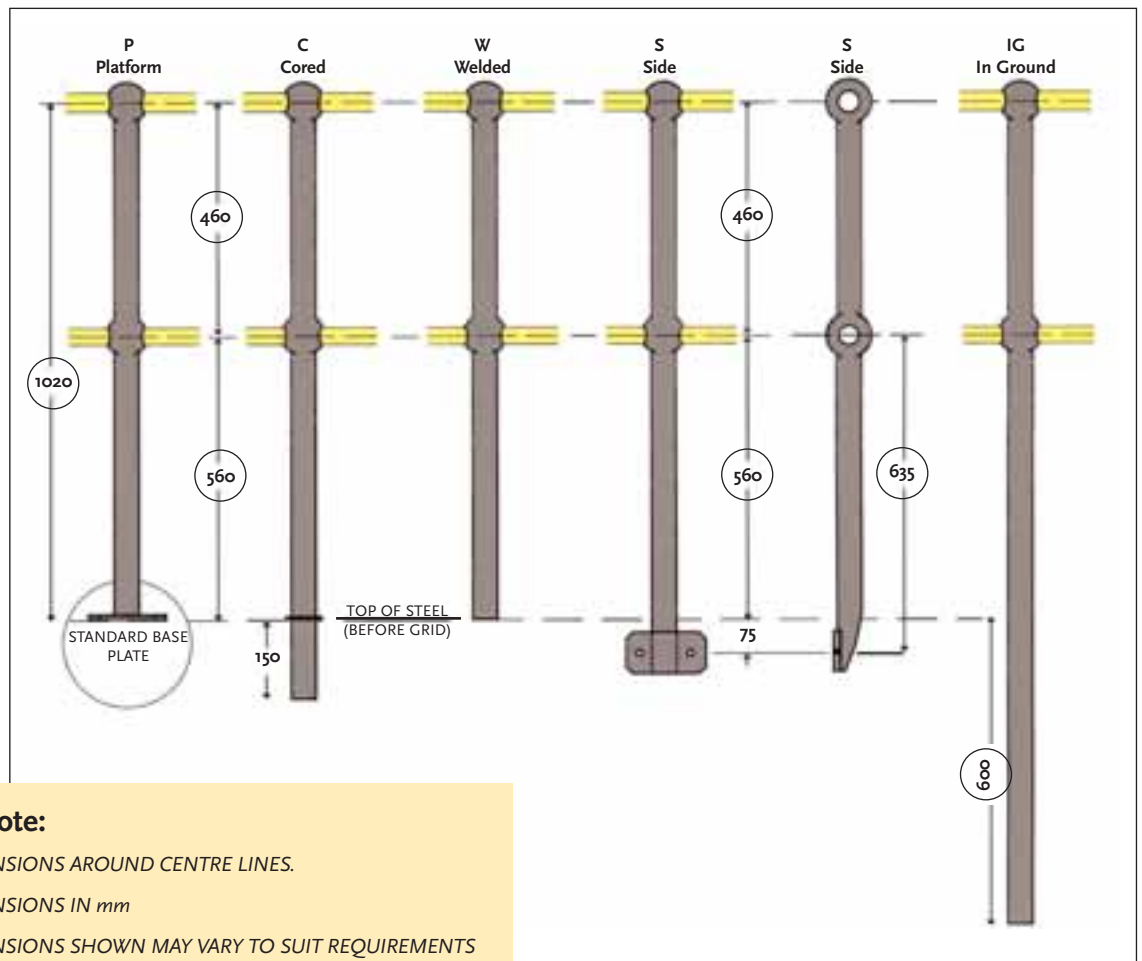

**Please Note:**

- ALL DIMENSIONS AROUND CENTRE LINES.
- ALL DIMENSIONS IN mm
- ALL DIMENSIONS SHOWN MAY VARY TO SUIT REQUIREMENTS
- ALL STANCHIONS AVAILABLE DRILLED ONE SIDE ONLY (D.O.S.O.)

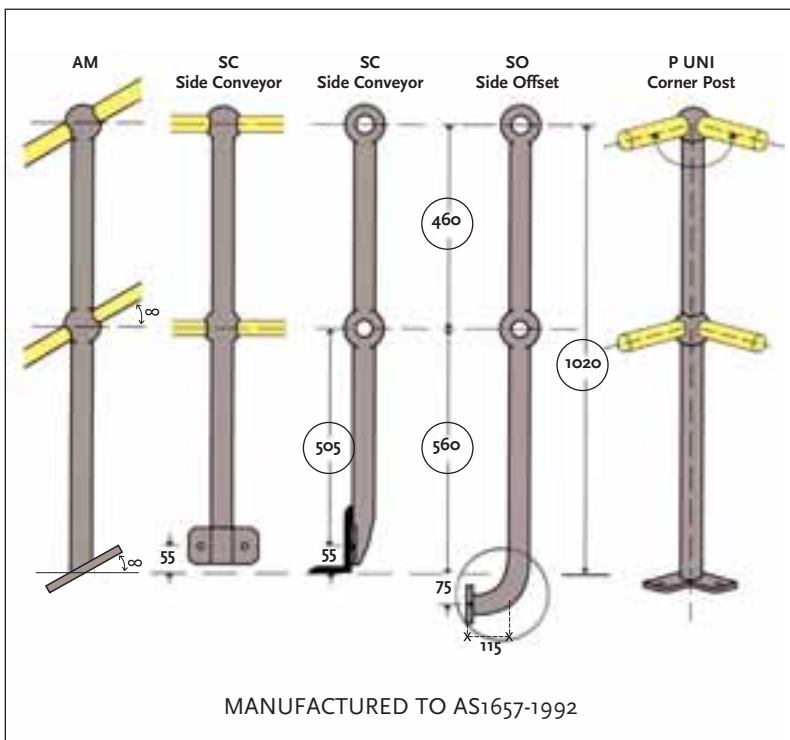

Sydney Tower  
Tourist Walk

\* BEFORE ORDERING:  
Check suitability of this dimension  
to match adjoining horizontal rail  
and adjust if necessary.

# Hand Rail and Grating Accessories

## Closure and Rail Bends

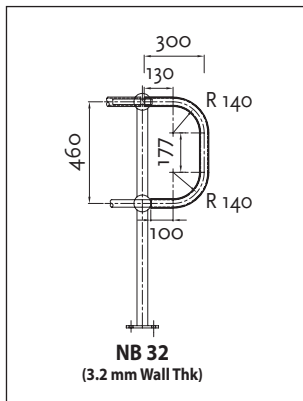

**End Closure Bends**  
• 3-HCB-GA

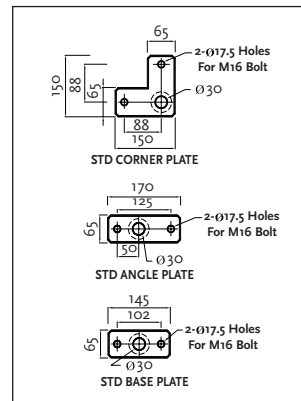

**Standard Base Plates**

- 2-SBP-UT

**AM Base Plates**

- 2-ABP-UT

**Corner Base Plates**

- 2-CBP-UT

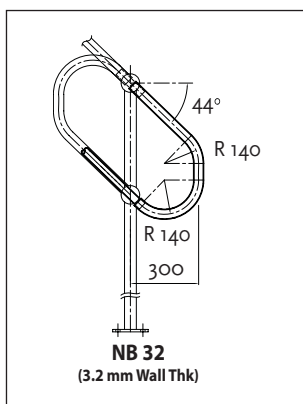

**Angle Closure Bends to suit AM Stanchions**  
• 3-ACB-44-GA

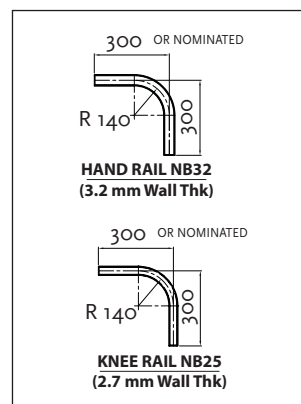

**Top Rail Bends**

- 3-RB32NB-GA

**Knee Rail Bends**

- 3-RB25NB-GA

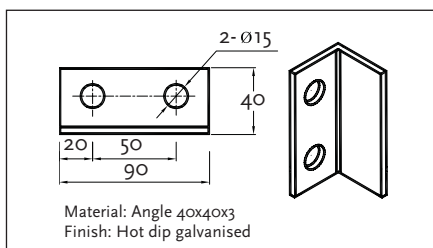

**Kickplate Plate Bracket**

- 3-KPB-GA

### Important note:

*A minimum of four clips per panel must be used to restrain floor panels. Where larger panels are to be fixed, it is advisable to use extra clips on any available intermediate supports.*

### 1. Field welding

Recommended for all permanently installed gratings, and for gratings that are to be removed only at infrequent intervals.

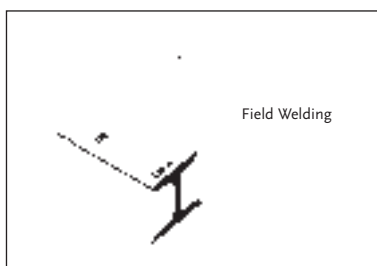

### 2. Fixing Clip

This can be secured quickly and safely by one man, working from the floor surface. Available in Boxes of 50

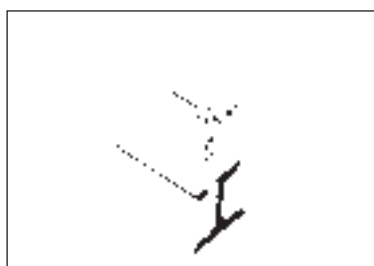

3-50CLIP-GA



# Loading Tables

## Light and medium duty (maximum recommended spans)

Load bar size	Maintenance floors No public use		Pedestrian traffic Public, residential and light use		Pedestrian traffic Public, commercial and crowd use	
	2.5Kpa Deflection = 5mm		3.0Kpa Deflection = 5mm		4.0Kpa Deflection = 5mm	
	Series 1	Series 2	Series 1	Series 2	Series 1	Series 2
RG 253	1410	1310	1350	1250	1250	1170
RG 323	1700	1580	1620	1510	1510	1400
RG 255	1590	1480	1520	1420	1420	1320
RG 3253	1910	1780	1820	1700	1700	1580
RG 4453	2420	2250	2310	2150	2150	2000
RG 5053	Not applicable		Not applicable		Not applicable	
RG 6574	Not applicable		Not applicable		Not applicable	
RG 7574	Not applicable		Not applicable		Not applicable	

## Heavy duty (maximum recommended spans)

Load bar size	General factories and workshops, motor rooms, wheel trolleys				General heavy loading areas, boiler equipment, heavy equipment areas			
	5.0Kpa				7.5Kpa			
	Deflection = 5mm		Deflection = 10mm		Deflection = 5mm		Deflection = 10mm	
	Series 1	Series 2	Series 1	Series 2	Series 1	Series 2	Series 1	Series 2
RG 253	Not applicable				Not applicable			
RG 323	Not applicable				Not applicable			
RG 255	1340	1250	1590	1480	1210	1130	1440	1340
RG 3253	1610	1500	1910	1780	1450	1350	1730	1610
RG 4453	2040	1890	2420	2250	1840	1710	2190	2040
RG 5053	2220	2070	2650	2460	2010	1870	2390	2230
RG 6574	2940	2730	3500	3250	2650	2470	3160	2940
RG 7574	3260	3040	3890	3620	2950	2750	3510	3270



Pohokura Oil Project







# Raised Expanded Metal

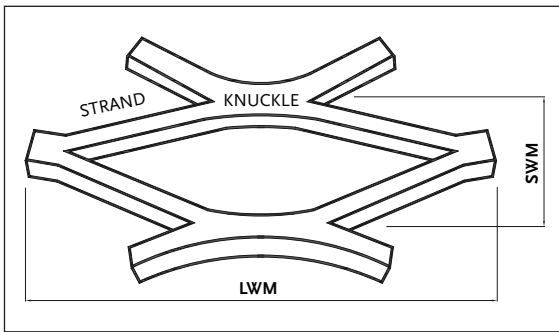

**EXPANDED METAL PATTERN TABLE**

Product Code	SWM (mm)	LWM (mm)	Strand Width (mm)	Thickness (mm)	Height (mm)
RG 50080	45	135	8	5	16
RG 50110	45	135	11	5	22
RG 50075	30	75	7.5	5	15
RG 50105	30	75	10.5	5	21

## LOAD AND DEFLECTION TABLE - EXPANDED MESH

This table is theoretical and is based on a uniformly distributed load of 100 kg/m<sup>2</sup> (1kPa)

Product Code	SWMXLWM	Strand Width (mm)	Thickness (mm)	Mass kg/m <sup>2</sup>	S Kpa	Span (mm) Simply Supported				
						600	750	900	1050	1200
RG 50080	45 x 135	8	5	14	S	1.6	2.6	3.6	5.0	6.5
					D	0.5	1.1	2.9	5.9	11.1
RG 50110	45 x 135	11	5	19	S	0.8	1.2	1.8	2.4	3.2
					D	0.4	1.0	2.2	4.6	7.4
RG 50075	30 x 75	7.5	5	22	S	1.2	2.0	2.7	3.6	4.7
					D	0.6	1.0	2.6	4.7	7.6
RG 50105	30 x 75	10.5	5	28	S	1.0	1.6	2.2	3.0	3.8
					D	0.4	0.8	1.7	3.1	4.6

Note: For uniformly distributed load other than 100kg/m<sup>2</sup> (1kPa) mesh stress and deflection can be calculated using the factor shown in the following table.

### Sample Calculation

Uniform Load: 200kg/m<sup>2</sup> (2kPa) → factor (i) of 2.0  
Grating Code: RG50080 Span: 900mm

Stress (S) = 3.6 x 2.0 = 7.2kg/mm<sup>2</sup>  
Deflection (D) = 2.9 x 2 = 5.8mm

### Stress and Deflection Factor

Uniform Load kg/m <sup>2</sup>	50	100	150	200
Factor (i)	0.5	1.0	1.5	2.0

S = Stress in kg / mm<sup>2</sup>

D = Deflection in mm

Allowable Stress = 18kg/mm<sup>2</sup> (180MPa)

Allowable Deflection = L(Span) / 300mm

## INSTALLATION TOLERANCES

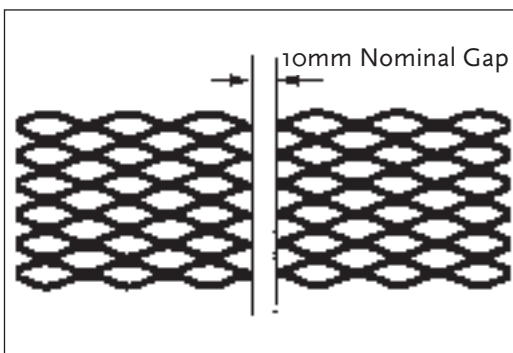

Expanded metal plates are not perfectly square. Maximum out of a square along edge is 5mm per 1000mm of length or 10mm on diagonals per square meter. Sheet must be resquared by shearing each side of the edge.

## Expanded Metal

Expanded metal is an economical and versatile material which can be used for enclosure, protection, support and decoration.

In the expanding process, expanded metal is made from a solid single sheet metal which is slit and stretched longitudinally. There is no weld or join in it, therefore loads are evenly distributed over a wide area.

The strands and knuckles form a uniform angle, which adds more strength and rigidity, even if one or more points are cut, the intersections of strand still can support the loads.

## MINIMUM SUPPORT DIMENSION 25mm

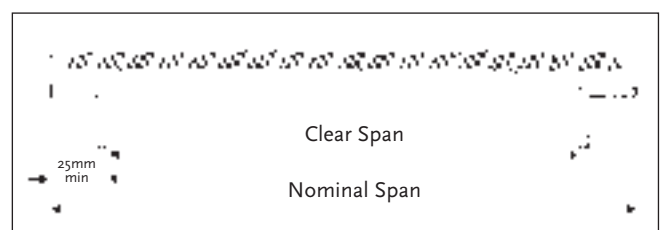

# Architectural Projects and Solutions

## Architectural

Rhino grating offers opportunities for cost effect, but highly innovative site platforms. Unique products such as Rhino Heel Guard give the Architect a system for providing safe non-intrusive, public access to environmentally or heritage sensitive sites. These products come in a range of materials from hot dipped galvanised steel to 316 stainless steel.



*Heelguard Mild Steel  
for Public Areas*



*Kirrabilli Harbour Walk Mild  
Steel Walk Way*



*Heelguard Stainless Steel*



*National Parks Track for Wheel  
Chair Access and  
Protection of Flora*



*Winner of Architectural Award (Agna)*



*Disable Wheel Chair  
Access Walk*



*Viewing Platform Sydney Harbour*

For further information on the products please contact RHINO GRATING for full specification and free design service.